

750K/850K DOZERS

123–152 kW (165–205 hp)



JOHN DEERE



It's got your fingerprints all over it.

OK, maybe not **your** fingerprints. But equipment owners and operators like you had a hand in perfecting our EPA Final Tier (4)/EU Stage IV K-Series Dozers. Armed with real-world experience, participants in our Customer Advocate Group (CAG) offered their expertise. We listened and responded with numerous enhancements including diesel engines for generous displacement, power, and lugging ability. Standard Eco mode for improved fuel efficiency with no loss of productivity. Spacious cabs that are noticeably quieter and more comfortable. And best-in-class serviceability features such as a new ground-level air cleaner and an innovative easy-to-clean V-cool package. Add the unsurpassed operating ease and maneuverability for which our dozers are known, and the K-Series is an obvious choice.

Model	Dozer Blade	Rated Power	Base Weight
750K XLT	Power-Angle-Tilt (PAT)	123 kW (165 hp)	15 661 kg (34,527 lb.)
750K LGP	PAT	123 kW (165 hp)	17 121 kg (37,745 lb.)
750K	Outside Dozer (OSD)	123 kW (165 hp)	15 679 kg (34,566 lb.)
850K	OSD	152 kW (205 hp)	19 304 kg (42,558 lb.)
850K WT	OSD	152 kW (205 hp)	20 050 kg (44,202 lb.)
850K LGP	OSD	152 kW (205 hp)	21 775 kg (48,005 lb.)
850K XLT	PAT	152 kW (205 hp)	19 876 kg (43,818 lb.)
850K WLT	PAT	152 kW (205 hp)	20 481 kg (45,152 lb.)
850K LGP	PAT	152 kW (205 hp)	21 036 kg (46,376 lb.)



Ultimate Uptime, featuring John Deere WorkSight™, is a customizable support solution available exclusively from your Deere dealer. This flexible offering maximizes equipment availability with standard John Deere WorkSight capabilities that can help prevent future downtime and speed repairs when it does occur. In addition to the base John Deere WorkSight features, our dealers work with you to build an uptime package that meets the specific needs of your machine, fleet, project, and business, including customized maintenance and repair agreements, onsite parts availability, extended warranties, fluid sampling, response-time guarantees, and more.



Go beyond the limits of other dozers.

Packed full of production-boosting and fluid-efficiency advantages, our dozers do more without a lot of extra effort. State-of-the-art electronic controls put an operator in complete command of an arsenal of production-boosting hydrostatic advantages, including power turns, counterrotation, and infinitely variable travel speeds. New features like standard Eco mode will help save fuel without loss of productivity, adding more money to your bottom line. Nothing runs like a Deere.



When you order your dozer grade-control ready, our “open-architecture” design makes adding a grade-control system as easy as plugging in the components, calibrating, and going to work, whether your preference be Trimble, Leica, or a factory-installed Topcon 3D-MC² system.

Low-effort controls command the blade and full-featured hydrostatic drivetrain, ensuring predictable response at all times, in all conditions.

Infinitely variable range to 11 km/h (6.8 mph) gives total flexibility to match ground speed to the load. Travel can also be varied to fit specific applications, terrain conditions, or operating preferences — or limited to maximize undercarriage life.

Independent track control speeds up or slows down each side — for smooth, full-power turns. An automatic 10-percent power boost helps carry big blade loads through turns.

1. These dozers steer the same and maintain their preset speed whether working on level ground or a 2-to-1 slope. So there's never a need to cross-steer or ride a brake.
2. Counterrotation is another productivity-boosting feature. It enables an operator to overcome heavy corner loads and quickly reposition the blade on the go. Provides space-saving spot turns, too.
3. Simply set maximum desired ground speed, and the power-management system automatically maintains peak engine rpm and power efficiency without stalling or shifting.

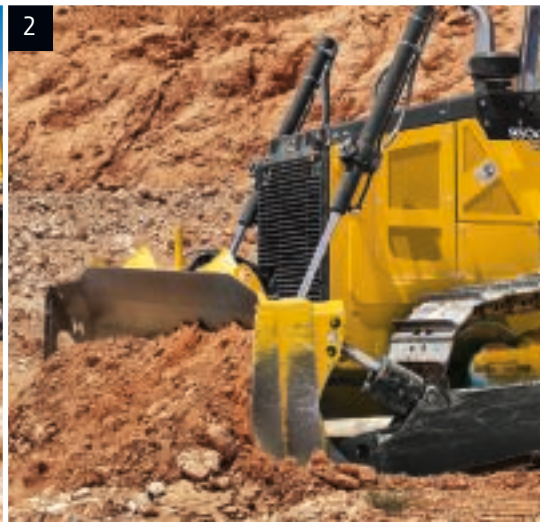

Get more done inside our comfort zone.

Of course you want your operators to be more productive. So why not put them in the seat of a K-Series Dozer's noticeably quiet and spacious cab? From ergonomically designed fully customizable controls to excellent overall visibility in all directions, these standard-setting dozers are loaded with everything you need to keep your operators comfortably productive — and on your payroll.

Standard high-back air-suspension seat and optional deluxe heated and leather-bolstered lower cushion adjust multiple ways for daylong comfort and support. Arm- and footrests also adjust.

Use the decelerator to slow both ground speed and engine rpm. Or ground speed only to help maintain traction without affecting engine power and hydraulic response. Fully depressing the pedal applies the brakes.

Oil-filled cab mounts and extensive insulation effectively isolate operators from vibration and noise. At just 76 dBA, the cab is noticeably quiet.

Beyond cup holders and cooler storage, there are plenty of places to store stuff. If you're running a grade-control system, the lockable in-dash storage (or permanent placement) of the monitor.

Exclusive Total Machine Control (TMC) monitor lets an operator select decelerator mode and response, forward/reverse ground-speed ranges, steering modulation, F-N-R shift rate, and forward/reverse speed ratios.

Fully modulated hydrostatic drivetrain ensures smooth moves, virtually eliminating jerky or abrupt movements.





1. Sealed-switch module (SSM) gives fingertip control of keyless start and enables exclusive features such as turbocharger cool-down and auto shutdown. Touchpad security system requires a numeric pass code (when enabled) to help prevent unauthorized machine operation.

2. Overhead radio and storage console includes a 12-volt electrical outlet for powering a cell phone or an iPod®.

3. Ergonomically correct joystick provides intuitive, low-effort control of steering, direction, and ground speed. It's detented so it doesn't require an operator's constant touch or attention, and employs a thumb-actuated travel-speed control switch.

A yellow John Deere bulldozer is shown from a low angle, pushing a large pile of reddish-brown earth. The bulldozer's blade is visible on the left, and its rear-mounted tracks and exhaust stacks are prominent. The John Deere logo is visible on the front grille. The background is a clear blue sky with some light clouds.

Nothing runs like a Deere, because nothing is built like it.

Designed and built with state-of-the-art tools and techniques by a quality-conscious workforce at our world-class facility in Dubuque, Iowa, the K-Series comes loaded with uptime-boosting features. Enhancements such as our unique V-cool system, new ground-level air cleaner, and EPA FT4/EU Stage IV diesel engines — plus traditional John Deere features such as one-piece unitized mainframes, DuraTrax™ undercarriages, wet-sleeve engine liners, and isolated planetary final drives — give our dozers the durability you need. When you know how they're built, you'll run these Deere.

Standard Eco mode automatically adjusts engine power and transmission settings based on load while maintaining ground speed, to help optimize fuel economy with no loss of productivity. Auto-idle helps save fuel by reducing engine speed when the dozer is not moving.

Variable-speed on-demand fan automatically speeds up or slows down, operating only as needed to keep things cool. Helps conserve power and fuel, while reducing noise.

One-piece welded mainframe resists torsional stress, absorbs shock loads, and delivers maximum strength while allowing easy service access to major components. Heavy-duty double-reduction planetary final drives are mounted independent of the track frames, where they're effectively protected from shock loads.

Reversing fan automatically backblows the cooler cores at preset intervals. When conditions demand more frequent cleaning, simply press a button to actuate the reversing cycle.

Engine pre-cleaner with aspiration lines provides higher filter efficiency for longer engine filter service life.

Available extended-life undercarriage delivers up to twice the bushing life, for extra durability in extremely abrasive conditions. If you want to further reduce maintenance and operating costs, choose the SC-2™ extended-life option.

Individually replaceable wet-sleeve engine-cylinder liners provide uniform engine cooling and long-term durability.

1. Our FT4/Stage IV diesels meet emission regulations without sacrificing power or torque. We built on our Interim Tier 4 (IT4)/Stage IIIB solution to deliver the best combination of performance, efficiency, and reliability. This technology is simple, fluid efficient, fully integrated, and fully supported. It employs field-proven cooled exhaust gas recirculation (EGR), easy-to-maintain high-uptime exhaust filters, and selective catalytic reduction (SCR).

2. Flush-fit bottom guards and tight-fitting side shields help keep trash out. Hood and side-shield perforations function as a "first filter," further preventing entry of most debris. Anything that gets past the five-mm holes also passes through the cooler cores.

3. V-cool design isolates coolers from dust and engine heat for increased efficiency and durability. Positioned behind the heavy-duty grille and fan, coolers are also less vulnerable.

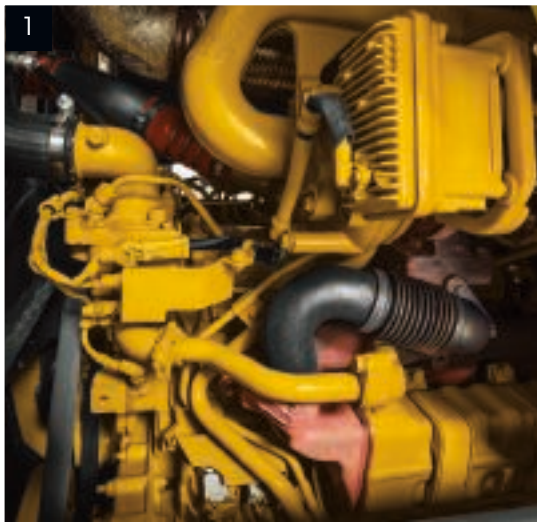

Precise grades, strong blades.

John Deere dozers enjoy solid reputations as superior grading machines. And for plenty of reasons. Unlike others that utilize the same mainframe with all dozers, our purpose-built design optimizes blade ratio and center of gravity for superior balance. So whether you opt for a power-angle-tilt (PAT) or an outside-mount straight or semi-U blade, you'll profit from uncompromised performance. Durability is also second-to-none. Advantages such as noticeably larger push beams, closed-cell blades, box-section C-frames, and steel-cable-supported Cordura®-covered hydraulic hoses provide long-term stamina and strength.

Cab-forward design provides a commanding view behind, below, and beyond the blade. Side and rear visibility is also unobstructed.

Generous hydraulic flow and precise metering ensure powerful and quick blade response, while providing the natural "feel" that enhances any operator's grading ability.

Hydraulic power-pitch option for outside-mount straight or semi-U blades allows the operator to control blade pitch from the cab, for improved ground penetration and load carrying. Using programmable return-to-pitch settings, which can be activated at the touch of a button, the operator can preset blade-pitch positions.

Four position settings on PAT dozers and infinite screw-type adjustment on outside-mount dozers allow you to easily fine-tune blade pitch to maximize productivity.

Optional electrohydraulic (EH) controls for both PAT and OSD blade configurations help move material smoothly and productively in all terrain conditions. They also simplify any grade-control installation.



1. PAT blade's heavy-duty ball-and-socket C-frame joint resists material buildup for long-term grading precision. Blade hoses are steel-cable supported and Cordura covered for extra protection.

2. Greaseless shim-adjustable clamshell bearings in the front and rear joints of the push beams ensure a tight connection for low-maintenance, "like-new" grading performance.

3. Heavy-duty cross-members provide solid lateral support and are shaped to allow a clear view of the bottom of the blade. What's more, their raised position allows generous clearance at the end of the push.

4. With heavy-duty high-profile push beams and a three-position pitch-adjustable semi-U blade, the outside-mount dozer delivers exceptional durability and high-production performance.

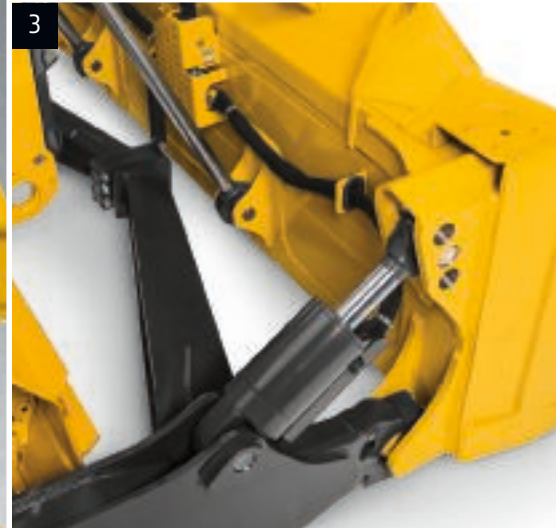



Configured, not compromised.

Yours isn't just any business. Why settle for just any dozer? With multiple undercarriage configurations, inside-mount PAT or outside-mount straight or semi-U blades, and numerous other options available, building a John Deere dozer your way is the way we do business. These highly versatile machines can also be equipped with special-duty and severe-application packages that help them thrive on a wide variety of jobsites. Tackle tasks that other dozers can't. Ask your dealer for details.



Model	Dozer Blade	Grouser Width
750K XLT	Power-Angle-Tilt (PAT)	560 mm (22 in.)
750K LGP	PAT	865 mm (34 in.)
750K	Outside Dozer (OSD)	560 mm (22 in.)
850K	OSD	610 mm (24 in.)
850K WT	OSD	760 mm (30 in.)
850K LGP	OSD	910 mm (36 in.)
850K XLT	PAT	610 mm (24 in.)
850K WLT	PAT	760 mm (30 in.)
850K LGP	PAT	910 mm (36 in.)

1. Protection packages and waste-handler configurations equip these dozers to survive, even thrive, in tough environments.
2. With their hydrostatic drivetrains and impressive drawbar pull, our dozers work well with rear-mount attachments such as rippers and cable plows.
3. High-intensity halogen driving lights are standard. But if you want to extend your workday beyond daylight, opt for the 360-deg. light package.

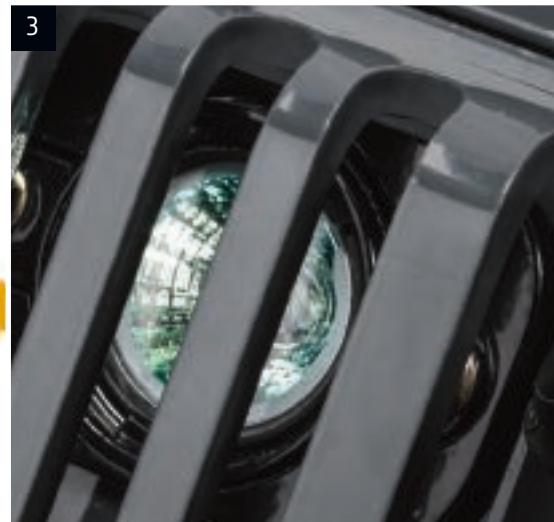
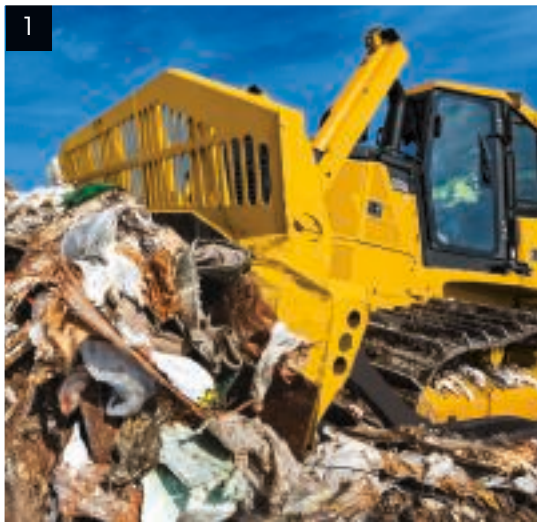

Designed with an open mind.

It takes only minutes to uncover the many ways our FT4/Stage IV K-Series helps minimize maintenance. Side shields swing open wide to reveal convenient same-side daily service points. An exclusive tilt-out fan box allows simplified access to cooler cores for quick cleanout. Other periodic service tasks such as fluid and filter changes are also refreshingly easy. Even gaining access to drivetrain components takes only minutes. As you can see, when it comes to keeping uptime up and daily operating costs down, we're pretty open-minded.

1. Available quick fluid-evacuation system helps speed servicing. 500-hour engine oil and 2,000-hour transmission and hydraulic fluid intervals decrease downtime and expense.

2. Fluid-sample and diagnostic test ports simplify preventive-maintenance work and troubleshooting for increased uptime.

3. Operator station tilts a full 70 deg. in only minutes, for wide-open drivetrain component access.

4. New ground-level air cleaner simplifies periodic service and is monitored by the onboard diagnostic system. Filters are common with many other John Deere crawler models.

5. Exhaust filter operation and status are indicated with icons and on-screen displays. The diagnostic monitor also provides easy-to-understand messages that help speed troubleshooting.

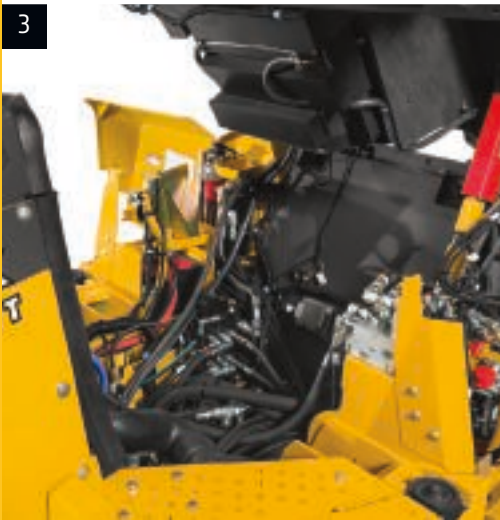
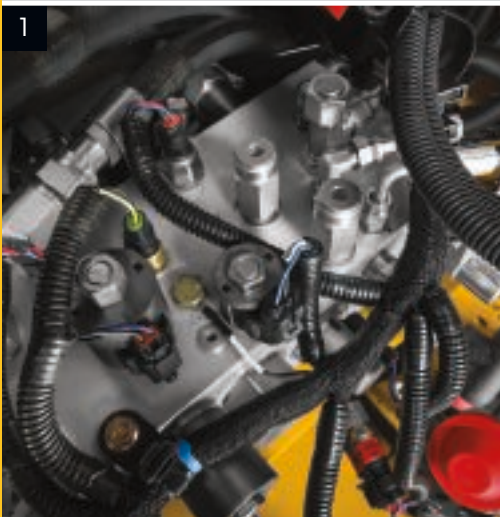

Ash-service intervals for the diesel particulate filter (DPF) are condition based, meaning the machine will notify the operator before service is required. Typically, ash service is not necessary until the first engine overhaul. Machine application, regular maintenance practices, and type of lubricating oil impact ash-service intervals.

Advanced diagnostic monitor provides easy-to-understand messages to help speed troubleshooting.

Heavy-duty recessed belly guards allow easy access to the engine oil pan for fast service.

Sealed hydraulic and hydrostatic reservoirs are separate, eliminating any possibility of cross-contamination.

Hinged side shields swing open wide for convenient access to dipsticks; fill tubes; batteries; master electrical shutoff; and engine, transmission, and hydraulic filters.

Remote lube banks provide easy access to difficult-to-reach crossbar and C-frame pivots. Convenient color-coded lube chart ensures that nothing gets overlooked.

Vertical filters allow quick, no-spill changes. Engine, hydraulics, and transmission utilize a common oil, further simplifying service.



John Deere WorkSight is an exclusive suite of telematic solutions that increases uptime while lowering operating costs. At its heart, JDLink Ultimate machine monitoring provides real-time data and health prognostics to suggest maintenance solutions that decrease costly downtime. Remote diagnostics enable your dealer to read codes, record performance data, and even update software without a trip to the jobsite.

750K

Engine	750K XLT / 750K LGP	750K
Blade Type	Power/Angle/Tilt (PAT)	Outside Dozer Blade (OSD)
Manufacturer and Model	John Deere PowerTech™ PVS 6068	John Deere PowerTech PVS 6068
Non-Road Emission Standard	EPA Final Tier 4/EU Stage IV	EPA Final Tier 4/EU Stage IV
Displacement	6.8 L (414 cu. in.)	6.8 L (414 cu. in.)
SAE Net Rated Power	123 kW (165 hp) at 1,800 rpm	123 kW (165 hp) at 1,800 rpm
Net Peak Torque	768 Nm (567 lb.-ft.) at 1,400 rpm	768 Nm (567 lb.-ft.) at 1,400 rpm
Aspiration	Turbocharged with charge air cooler	Turbocharged with charge air cooler
Air Cleaner	Vacuum-aspirated dual-element dry canister	Vacuum-aspirated dual-element dry canister
Cooling	750K XLT / 750K LGP / 750K	
Type	Variable-speed suction fan with automatic reversing	
Engine Coolant Rating	−37 deg. C (−34 deg. F)	
Engine Radiator	10 fins per in.	
Powertrain	750K XLT	
Transmission	Automatic, dual-path, hydrostatic drive; load-sensing feature automatically adjusts speed and power to match changing load conditions; each individually controlled track is powered by a variable-displacement piston pump and motor combination; ground-speed selection buttons on single-lever steering and direction control; independently selectable reverse speed ratios of 100%, 115%, or 130% of forward ground speed; decelerator pedal controls ground speed to stop	
System Relief Pressure	45 850 kPa (6,650 psi)	
Travel Speeds		
Forward and Reverse	9.7 km/h (6.0 mph)	
Maximum (optional)	11.0 km/h (6.8 mph)	
Steering	Single-lever steering, speed, direction control, and counterrotation; full power turns and infinitely variable track speeds provide unlimited maneuverability and optimum control; hydrostatic steering eliminates steering clutches and brakes	
Final Drives	Double-reduction, planetary final drives mounted independently of track frames and dozer push frames for isolation from shock loads	
Total Ratio	46.41 to 1	
Drawbar Pull		
Maximum	245 kN (55,000 lb.)	
At 1.9 km/h (1.2 mph)	156 kN (35,000 lb.)	
At 3.2 km/h (2.0 mph)	98 kN (22,000 lb.)	
Brakes		
Service	Hydrostatic (dynamic) braking stops the machine whenever the direction-control lever is moved to neutral or the decelerator is depressed to the detent	

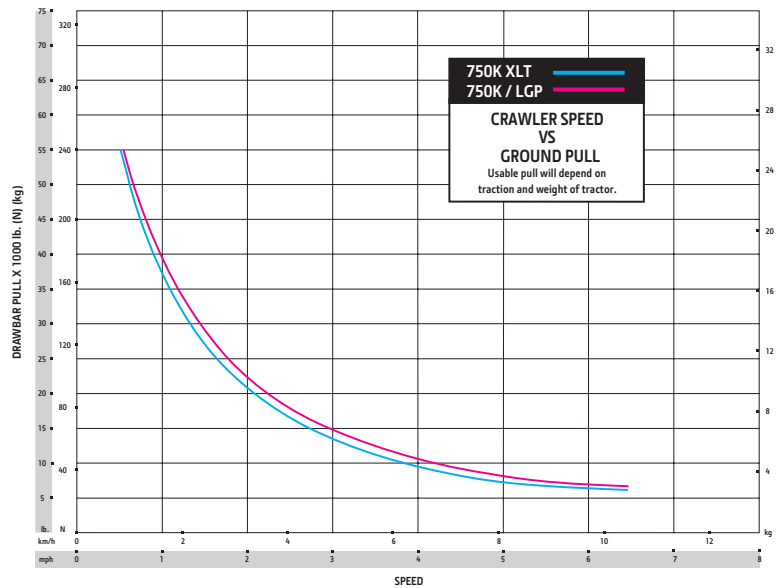



Powertrain (continued)		750K XLT / 750K LGP / 750K	
Brakes (continued)			
Parking	Exclusive spring-applied, hydraulically released park brake safety feature engages wet, multiple-disc brakes automatically whenever the engine stops, the operator depresses the decelerator pedal to the brake position, the unit is in neutral for 3 seconds (with detected motion), or the park-lock lever is in the park position; machine cannot be driven with brake applied, minimizing wearout or need for adjustment		
Hydraulics		750K XLT / 750K LGP	750K
Blade Type	PAT		OSD
Type	Load sense hydraulic system with variable-displacement piston pump		Load sense hydraulic system with variable-displacement piston pump
Pump Displacement	63 cc		63 cc
System Relief Pressure	24 993 kPa (3,625 psi)		24 993 kPa (3,625 psi)
Differential Pressure	1896 kPa (275 psi)		1896 kPa (275 psi)
Maximum Flow at Unloaded High Idle	138 L/m (36 gpm)		138 L/m (36 gpm)
Control	3-function hydraulic-pilot T-bar joystick with pushbutton angle function		2-function hydraulic-pilot T-bar joystick
Electrical		750K XLT / 750K LGP / 750K	
Voltage	24 volts		
Capacity			
Battery	950 CCA		
Reserve	190 min.		
Alternator Rating			
Cab	130 amp		
Canopy	100 amp		
Lights	Grille mounted (2), rear mounted (2), engine compartment (1), and rear reflectors (2)		
Undercarriage		750K XLT	750K LGP
Blade Type	PAT	PAT	OSD
Tracks	John Deere Dura-Trax™ features large deep-heat-treated, sealed, and lubricated track links and through-hardened, sealed, and lubricated rollers for maximum wear resistance; sprockets are segmented; extreme-duty shoes are available (on some models) for severe applications		
Track Gauge	1880 mm (74 in.)	2134 mm (84 in.)	1880 mm (74 in.)
Grouser Width	560 mm (22 in.)	865 mm (34 in.)	560 mm (22 in.)
Chain	Sealed and lubricated	Sealed and lubricated	Sealed and lubricated
Shoes, Each Side	45	45	40
Track Rollers, Each Side	8	8	7
Track Length on Ground	3073 mm (121 in.)	3073 mm (121 in.)	2591 mm (102 in.)
Ground Contact Area	34 344 cm ² (5,323 sq. in.)	53 077 cm ² (8,227 sq. in.)	28 957 cm ² (4,488 sq. in.)
Ground Pressure	44.5 kPa (6.46 psi)	31.5 kPa (4.57 psi)	52.9 kPa (7.67 psi)
Track Pitch	191 mm (7.5 in.)	191 mm (7.5 in.)	191 mm (7.5 in.)
Oscillation at Front Roller	± 135 mm (± 5.3 in.)	± 127 mm (± 5.0 in.)	± 110 mm (± 4.3 in.)
Operator Station		750K XLT / 750K LGP / 750K	
ROPS (ISO 3471 – 2008) and FOPS (ISO 3449 – 2005)			
Serviceability			
Refill Capacities			
Fuel Tank with Lockable Cap	368 L (97.5 gal.)		
Cooling System with Recovery Tank	40.75 L (10.8 gal.)		
Engine Oil with Filter	24.6 L (6.5 gal.)		
Reservoir with Filter			
Transmission	115 L (30 gal.)		
Hydraulic	112 L (29.7 gal.)		
Diesel Exhaust Fluid (DEF) Reservoir	13.6 L (3.6 gal.)		

Operating Weights	750K XLT	750K LGP	750K
Blade Type	PAT	PAT	OSD
<i>Base Weight (with standard equipment, rollover protective structure [ROPS], full fuel tank, and 79-kg [175 lb.] operator)</i>	15 661 kg (34,527 lb.)	17 121 kg (37,745 lb.)	15 679 kg (34,566 lb.)
Optional Components			
Cab with Pressurizer and Heater/Air Conditioner	337 kg (743 lb.)	337 kg (743 lb.)	337 kg (743 lb.)
ROPS Canopy			
Heater	39 kg (85 lb.)	39 kg (85 lb.)	39 kg (85 lb.)
Front and Door Screens	84 kg (186 lb.)	84 kg (186 lb.)	84 kg (186 lb.)
Rear Screen	23 kg (50 lb.)	23 kg (50 lb.)	23 kg (50 lb.)
Side Screens	44 kg (98 lb.)	44 kg (98 lb.)	44 kg (98 lb.)
Cab with Air Conditioner			
Front and Door Screens	79 kg (175 lb.)	79 kg (175 lb.)	79 kg (175 lb.)
Rear Screen	34 kg (75 lb.)	34 kg (75 lb.)	34 kg (75 lb.)
Side Screens	54 kg (120 lb.)	54 kg (120 lb.)	54 kg (120 lb.)
Condenser Guard (cab with air conditioner)	55 kg (121 lb.)	55 kg (121 lb.)	55 kg (121 lb.)
Limb Risers (ROPS canopy and cab)	261 kg (575 lb.)	261 kg (575 lb.)	261 kg (575 lb.)
Heavy-Duty Grille	28 kg (62 lb.)	28 kg (62 lb.)	28 kg (62 lb.)
Lift-Cylinder Hose Guards	42 kg (93 lb.)	42 kg (93 lb.)	77 kg (170 lb.)
Tank Guards	323 kg (712 lb.)	323 kg (712 lb.)	323 kg (712 lb.)
Rear Counterweight	326 kg (720 lb.)	326 kg (720 lb.)	326 kg (720 lb.)
Retrieval Hitch	37 kg (81 lb.)	37 kg (81 lb.)	37 kg (81 lb.)
Drawbar, Extended Rigid	130 kg (286 lb.)	130 kg (286 lb.)	130 kg (286 lb.)
Blade Brush Guard	87 kg (192 lb.)	87 kg (192 lb.)	87 kg (192 lb.)
Center Chain Guides	61 kg (135 lb.)	61 kg (135 lb.)	61 kg (135 lb.)
Full-Length Rock Guards	154 kg (340 lb.)	154 kg (340 lb.)	174 kg (384 lb.)
Track Shoes			
560-mm (22 in.) Moderate Duty	In base	—	In base
560-mm (22 in.) Extreme Duty	134 kg (296 lb.)	—	119 kg (263 lb.)
610-mm (24 in.) Moderate Duty	140 kg (309 lb.)	—	125 kg (275 lb.)
610-mm (24 in.) Extreme Duty	289 kg (637 lb.)	—	257 kg (566 lb.)
710-mm (28 in.) Moderate Duty	—	- 418 kg (- 922 lb.)	—
865-mm (34 in.) Moderate Duty	—	In base	—
Machine Dimensions			
Blade Type	PAT	PAT	OSD
A Overall Height to Roof	3128 mm (10 ft. 3 in.)	3128 mm (10 ft. 3 in.)	3128 mm (10 ft. 3 in.)
B Tread Depth with Single-Bar Grouser			
Moderate Duty	56 mm (2.2 in.)	56 mm (2.2 in.)	56 mm (2.2 in.)
Extreme Duty	69 mm (2.7 in.)	69 mm (2.7 in.)	69 mm (2.7 in.)
C Ground Clearance in Dirt	356 mm (14 in.)	356 mm (14 in.)	356 mm (14 in.)
D Overall Length	4921 mm (16 ft. 5 in.)	5246 mm (17 ft. 3 in.)	4937 mm (16 ft. 2 in.)
Length with Extended Drawbar	5210 mm (17 ft. 1 in.)	5535 mm (18 ft. 2 in.)	5226 mm (17 ft. 2 in.)
E Blade Lift Height	1025 mm (40.3 in.)	1025 mm (40.3 in.)	1050 mm (41.3 in.)
F Blade Digging Depth	650 mm (25.6 in.)	650 mm (25.6 in.)	575 mm (22.6 in.)
G Blade Cutting-Edge Angle, Adjustable	55.2 to 60.1 deg.	55.2 to 60.1 deg.	50.5 to 60.0 deg.

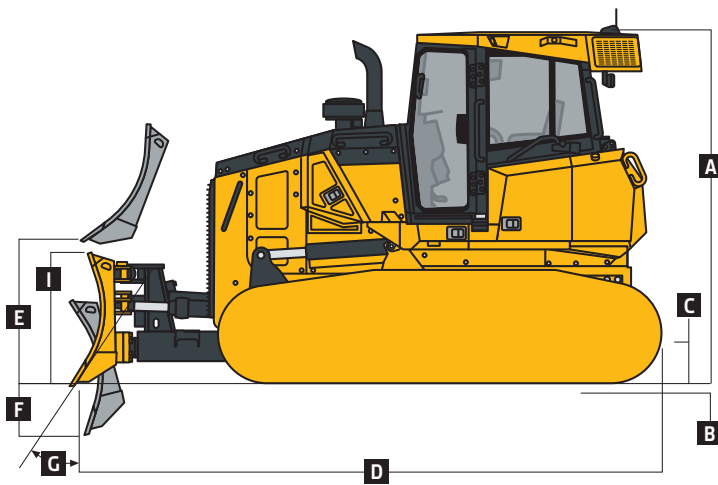

750K XLT / 750K LGP WITH POWER-ANGLE-TILT (PAT) BLADE

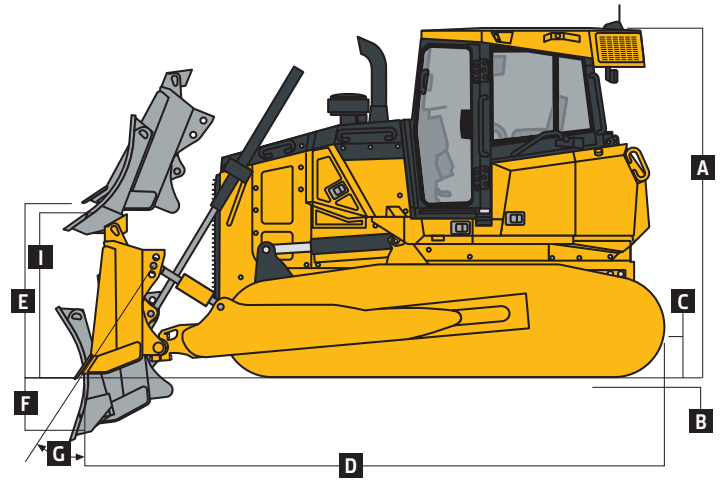

750K WITH OUTSIDE DOZER (OSD) BLADE

Machine Dimensions <i>(continued)</i>	750K XLT	750K LGP	750K
Blade Type	<i>PAT</i>	<i>PAT</i>	<i>OSD</i>
Semi-U			
H Blade Width	—	—	3251 mm (128 in.) (10 ft. 8 in.)
I Blade Height	—	—	1240 mm (48.8 in.) (4 ft. 0.8 in.)
SAE Capacity	—	—	4.3 m ³ (5.6 cu. yd.)
Weight	—	—	1163 kg (2,564 lb.)
Push-Beam Assembly Weight (without blade)	—	—	1470 kg (3,242 lb.)
L Blade Tilt	—	—	711 mm (28 in.)
N Width Over Track	—	—	2438 mm (96 in.) (8 ft. 0 in.)
Straight			
H Blade Width	3296 mm (130 in.) (10 ft. 10 in.)	3962 mm (156 in.) (13 ft. 0 in.)	—
I Blade Height	1194 mm (47 in.) (3 ft. 11 in.)	1170 mm (46.1 in.) (3 ft. 10.1 in.)	—
SAE Capacity	2.2 m ³ (4.2 cu. yd.)	3.8 m ³ (5.0 cu. yd.)	—
Weight	937 kg (2,066 lb.)	1081 kg (2,383 lb.)	—
C-Frame Assembly Weight (without blade)	1318 kg (2,905 lb.)	1318 kg (2,905 lb.)	—
J Blade Angle	23.5 deg.	23.5 deg.	—
K Overall Width with Blade Angled	3020 mm (118.9 in.) (9 ft. 10.9 in.)	3631 mm (142.9 in.) (11 ft. 10.9 in.)	—
L Blade Tilt (uses tilt jack)	437 mm (17.2 in.)	524 mm (20.6 in.)	—
M Cut Reach	108 mm (4.3 in.)	84 mm (3.3 in.)	—
N Width Over Track	2438 mm (96 in.) (8 ft. 0 in.)	2997 mm (118 in.) (9 ft. 10 in.)	—
O Cast Reach	224 mm (8.8 in.)	297 mm (11.7 in.)	—

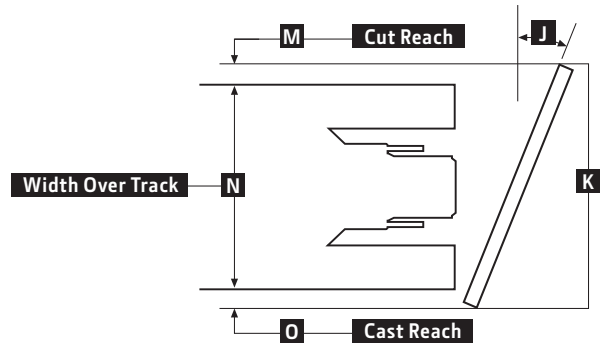
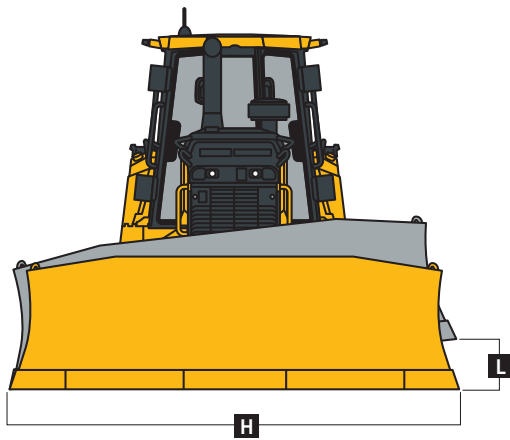

Rear Ripper 750K XLT / 750K LGP / 750K

Multi-shank (3) parallelogram ripper with hydraulic pitch adjustment and ESCO® ripper tips	
Weight	1690 kg (3,725 lb.)
P Maximum Penetration	686 mm (27 in.)
Q Maximum Clearance Under Tip	686 mm (27 in.)
R Overall Length, Lowered Position	1689 mm (5 ft. 7 in.)
R^l Overall Length, Raised Position	1448 mm (4 ft. 9 in.)
S Overall Beam Width	2134 mm (7 ft. 0 in.)
T Slope Angle (full raise)	22 deg.
U Ripping Width	1880 mm (6 ft. 2 in.)
V Distance Between Shanks	902 mm (3 ft. 0 in.)

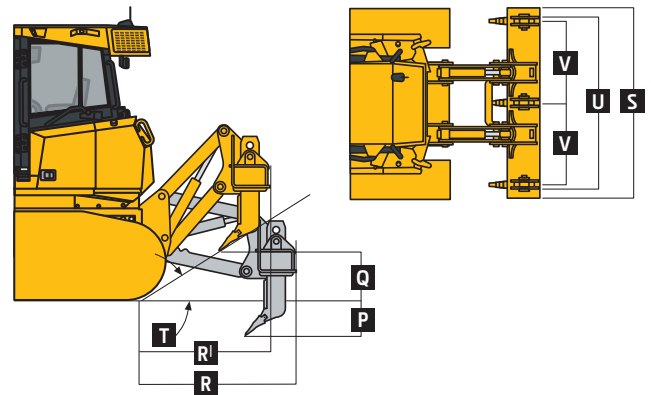

850K

Engine	850K XLT / 850K WLT / 850K LGP	850K / 850K WT / 850K LGP
Blade Type	Power-Angle-Tilt (PAT)	Outside Dozer (OSD)
Manufacturer and Model	John Deere PowerTech™ PSS 6068	John Deere PowerTech PSS 6068
Non-Road Emission Standard	EPA Final Tier 4/EU Stage IV	EPA Final Tier 4/EU Stage IV
Displacement	6.8L (414 cu. in.)	6.8L (414 cu. in.)
SAE Net Rated Power	152 kW (205 hp) at 1,800 rpm	152 kW (205 hp) at 1,800 rpm
Net Peak Torque	915 Nm (675 ft.-lb.) at 1,500 rpm	915 Nm (675 ft.-lb.) at 1,500 rpm
Aspiration	Turbocharged with charge-air cooler	Turbocharged with charge-air cooler
Air Cleaner	Vacuum-aspirated dual-element dry canister	Vacuum-aspirated dual-element dry canister
Cooling	850K XLT / 850K WLT / 850K LGP / 850K / 850K WT	
Type	Variable-speed suction fan with automatic reversing	
Engine Coolant Rating	-37 deg. C. (-34 deg. F)	
Engine Radiator	10 fins per in.	

Powertrain	
Transmission	Automatic, dual-path, hydrostatic drive; load-sensing feature automatically adjusts speed and power to match changing load conditions; each individually controlled track is powered by a variable-displacement piston pump and motor combination; ground-speed selection buttons on single-lever steering and direction control; independently selectable reverse speed ratios of 100%, 115%, or 130% of forward ground speed; decelerator pedal controls ground speed to stop
System Relief Pressure	45 850 kPa (6,650 psi)
Travel Speeds	
Forward and Reverse	9.7 km/h (6.0 mph)
Maximum (optional)	11.0 km/h (6.8 mph)
Steering	Single-lever steering, speed, direction control, and counterrotation; full power turns and infinitely variable track speeds provide unlimited maneuverability and optimum control; hydrostatic steering eliminates steering clutches and brakes
Final Drives	Double-reduction, planetary final drives mounted independently of track frames and dozer push frames for isolation from shock loads
Total Ratio	44.75 to 1

Drawbar Pull	
Maximum	344 kN (77,300 lb.)
At 1.9 km/h (1.2 mph)	178 kN (40,000 lb.)
At 3.2 km/h (2.0 mph)	131 kN (29,500 lb.)

Brakes	
Service	Hydrostatic (dynamic) braking stops machine whenever the direction/steering-control lever is moved to neutral or the decelerator is depressed to the end of travel
Parking	Exclusive spring-applied, hydraulically released park brake safety feature engages wet, multiple-disc brakes automatically whenever the engine stops, the operator depresses the decelerator pedal to the brake position, the unit is in neutral for 3 seconds (with detected motion), or the park-lock lever is in the park position; machine cannot be driven with brake applied, minimizing wearout or need for adjustment

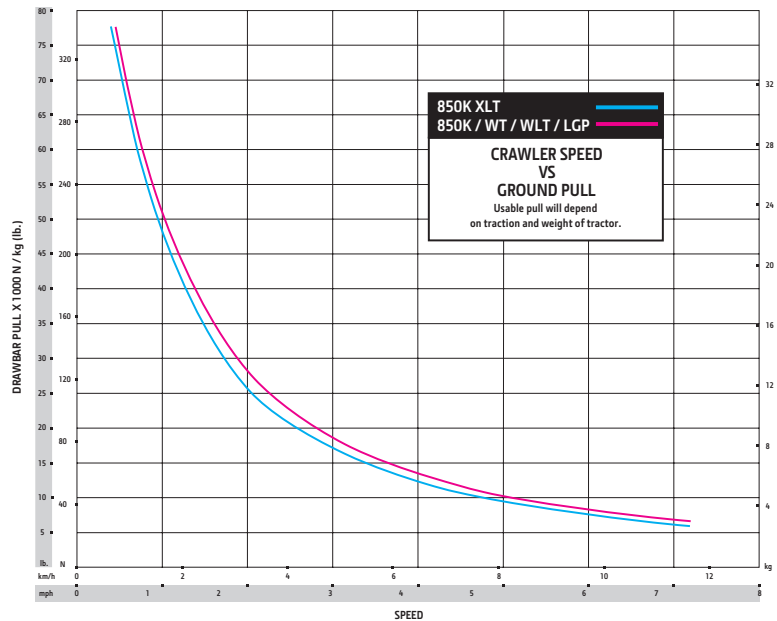

Hydraulics	850K XLT / 850K WLT / 850K LGP	850K / 850K WT / 850K LGP
Blade Type	PAT	OSD
Type	Load-sense hydraulic system with variable-displacement piston pump	
Pump Displacement	74 cc	74 cc
System Relief Pressure	24 993 kPa (3,625 psi)	24 993 kPa (3,625 psi)
Differential Pressure	1896 kPa (275 psi)	1896 kPa (275 psi)

Operating Weights <i>(continued)</i>	850K XLT	850K WLT	850K LGP	850K	850K WT	850K LGP
Blade Type	PAT	PAT	PAT	OSD	OSD	OSD
Optional Components <i>(continued)</i>						
Heavy-Duty Grille	35 kg (78 lb.)	35 kg (78 lb.)	35 kg (78 lb.)	35 kg (78 lb.)	35 kg (78 lb.)	35 kg (78 lb.)
Lift-Cylinder Hose Guards	42 kg (93 lb.)	42 kg (93 lb.)	42 kg (93 lb.)	80 kg (176 lb.)	80 kg (176 lb.)	80 kg (176 lb.)
Tank Guards	323 kg (712 lb.)	323 kg (712 lb.)	323 kg (712 lb.)	323 kg (712 lb.)	323 kg (712 lb.)	323 kg (712 lb.)
Counterweight						
Front	397 kg (875 lb.)	397 kg (875 lb.)	397 kg (875 lb.)	397 kg (875 lb.)	397 kg (875 lb.)	397 kg (875 lb.)
Rear	449 kg (990 lb.)	449 kg (990 lb.)	449 kg (990 lb.)	449 kg (990 lb.)	449 kg (990 lb.)	449 kg (990 lb.)
Retrieval Hitch	52 kg (114 lb.)	52 kg (114 lb.)	52 kg (114 lb.)	52 kg (114 lb.)	52 kg (114 lb.)	52 kg (114 lb.)
Drawbar, Extended Rigid	130 kg (286 lb.)	130 kg (286 lb.)	130 kg (286 lb.)	130 kg (286 lb.)	130 kg (286 lb.)	130 kg (286 lb.)
Blade Brush Guard	87 kg (192 lb.)	87 kg (192 lb.)	87 kg (192 lb.)	87 kg (192 lb.)	87 kg (192 lb.)	87 kg (192 lb.)
Blade Trash Rack	—	198 kg (436 lb.)	210 kg (462 lb.)	—	207 kg (455 lb.)	226 kg (498 lb.)
Center Chain Guides	85 kg (188 lb.)	85 kg (188 lb.)	85 kg (188 lb.)	85 kg (188 lb.)	85 kg (188 lb.)	85 kg (188 lb.)
Full-Length Rock Guards	242 kg (534 lb.)	242 kg (534 lb.)	242 kg (534 lb.)	222 kg (490 lb.)	222 kg (490 lb.)	242 kg (534 lb.)
Final-Drive Trash Guards	70 kg (155 lb.)	70 kg (155 lb.)	70 kg (155 lb.)	70 kg (155 lb.)	70 kg (155 lb.)	70 kg (155 lb.)
Striker Bars						
Front	—	73 kg (160 lb.)	73 kg (160 lb.)	—	111 kg (245 lb.)	147 kg (325 lb.)
Rear	—	78 kg (171 lb.)	78 kg (171 lb.)	—	166 kg (366 lb.)	78 kg (171 lb.)
Pre-Cleaner						
Powered Cab Air	21 kg (47 lb.)	21 kg (47 lb.)	21 kg (47 lb.)	21 kg (47 lb.)	21 kg (47 lb.)	21 kg (47 lb.)
Rotary Ejector Engine Air	6 kg (13 lb.)	6 kg (13 lb.)	6 kg (13 lb.)	6 kg (13 lb.)	6 kg (13 lb.)	6 kg (13 lb.)
Track Shoes						
560-mm (22 in.) Extreme Duty	175 kg (385 lb.)	—	—	155 kg (342 lb.)	-213 kg (-470 lb.)	—
610-mm (24 in.) Moderate Duty	In base	—	-850 kg (-1,873 lb.)	In base	-368 kg (-812 lb.)	-847 kg (-1,868 lb.)
610-mm (24 in.) Extreme Duty	346 kg (762 lb.)	—	-504 kg (-1,111 lb.)	307 kg (677 lb.)	-61 kg (-135 lb.)	-502 kg (-1,108 lb.)
760-mm (30 in.) Moderate Duty	—	In base	-435 kg (-959 lb.)	—	In base	—
760-mm (30 in.) Extreme Duty	—	444 kg (979 lb.)	9 kg (19 lb.)	—	395 kg (870 lb.)	—
910-mm (36 in.) Moderate Duty	—	—	In base	—	—	In base
910-mm (36 in.) Extreme Duty	—	—	524 kg (1,155 lb.)	—	—	523 kg (1,153 lb.)
Machine Dimensions						
A Overall Height to Roof	3211 mm (10 ft. 6.5 in.)		3211 mm (10 ft. 6.5 in.)		3211 mm (10 ft. 6.5 in.)	
B Tread Depth with Single-Bar Grouser	66 mm (2.6 in.)		66 mm (2.6 in.)		66 mm (2.6 in.)	
Moderate Duty	66 mm (2.6 in.)	66 mm (2.6 in.)	66 mm (2.6 in.)	66 mm (2.6 in.)	66 mm (2.6 in.)	66 mm (2.6 in.)
Extreme Duty	71 mm (2.8 in.)	71 mm (2.8 in.)	71 mm (2.8 in.)	71 mm (2.8 in.)	71 mm (2.8 in.)	71 mm (2.8 in.)
C Ground Clearance in Dirt	409 mm (16.1 in.)		409 mm (16.1 in.)		409 mm (16.1 in.)	
D Overall Length	5740 mm (18 ft. 10 in.)	5740 mm (18 ft. 10 in.)	5740 mm (18 ft. 10 in.)	5384 mm (17 ft. 8 in.)	5384 mm (17 ft. 8 in.)	5940 mm (19 ft. 6 in.)
Length with Extended Drawbar	5937 mm (19 ft. 6 in.)	5937 mm (19 ft. 6 in.)	5937 mm (19 ft. 6 in.)	5569 mm (18 ft. 3 in.)	5569 mm (18 ft. 3 in.)	6137 mm (20 ft. 2 in.)
E Blade Lift Height	1072 mm (3 ft. 6 in.)	1072 mm (3 ft. 6 in.)	1072 mm (3 ft. 6 in.)	1151 mm (3 ft. 9 in.)	1151 mm (3 ft. 9 in.)	1151 mm (3 ft. 9 in.)
F Blade Digging Depth	704 mm (28 in.)	704 mm (28 in.)	704 mm (28 in.)	599 mm (24 in.)	599 mm (24 in.)	599 mm (24 in.)
G Blade Cutting-Edge Angle, Adjustable	55.1 to 60.2 deg.	55.1 to 60.2 deg.	55.1 to 60.2 deg.	51.5 to 61.0 deg.	51.5 to 61.0 deg.	51.5 to 61.0 deg.

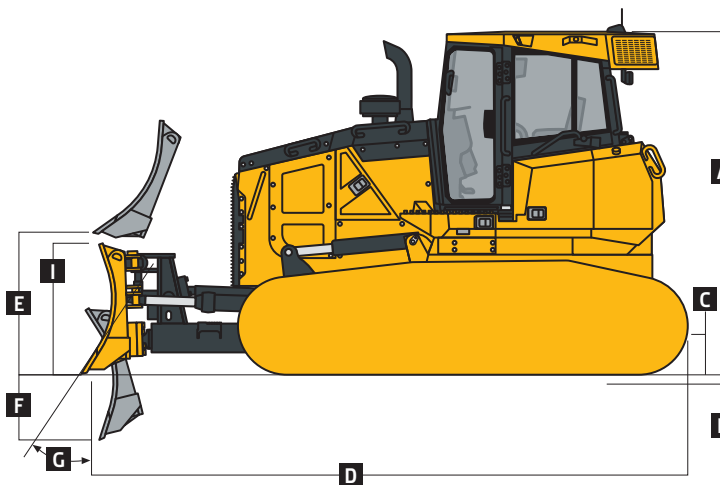

850K XLT / 850K WLT / 850K LGP WITH POWER-ANGLE-TILT (PAT) BLADE

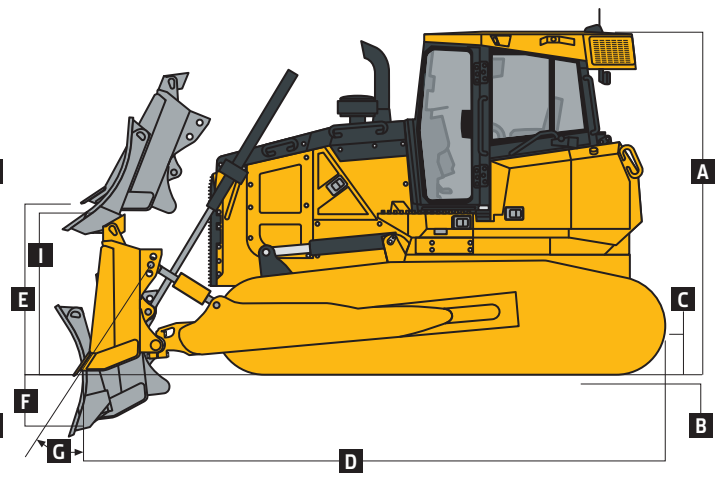

850K / 850K WT / 850K LGP WITH OUTSIDE DOZER (OSD) BLADE

Machine Dimensions <i>(continued)</i>	850K XLT	850K WLT	850K LGP	850K	850K WT	850K LGP
Blade Type	<i>PAT</i>	<i>PAT</i>	<i>PAT</i>	<i>OSD</i>	<i>OSD</i>	<i>OSD</i>
	—	—	—	Semi-U	—	—
H Blade Width	—	—	—	3251 mm (128 in.) (10 ft. 8 in.)	3556 mm (140 in.) (11 ft. 8 in.)	3861 mm (152 in.) (12 ft. 8 in.)
I Blade Height	—	—	—	1422 mm (56 in.) (4 ft. 8 in.)	1374 mm (54 in.) (4 ft. 6 in.)	1321 mm (52 in.) (4 ft. 4 in.)
SAE Capacity	—	—	—	5.6 m ³ (7.3 cu. yd.)	5.8 m ³ (7.6 cu. yd.)	6.0 m ³ (7.8 cu. yd.)
Weight	—	—	—	1643 kg (3,286 lb.)	1567 kg (3,455 lb.)	1641 kg (3,612 lb.)
Push-Beam Assembly Weight (without blade)	—	—	—	1820 kg (4,004 lb.)	1889 kg (4,156 lb.)	2,101 kg (4,622 lb.)
L Blade Tilt	—	—	—	753 mm (30 in.)	753 mm (30 in.)	853 mm (34 in.)
N Width Over Track	—	—	—	2489 mm (98 in.) (8 ft. 2 in.)	2794 mm (110 in.) (9 ft. 2 in.)	3099 mm (122 in.) (10 ft. 2 in.)
	PAT			Straight		
H Blade Width	3708 mm (146 in.) (12 ft. 2 in.)	4013 mm (158 in.) (13 ft. 2 in.)	4267 mm (168 in.) (14 ft. 0 in.)	—	—	3912 mm (154 in.) (12 ft. 10 in.)
I Blade Height	1229 mm (48 in.) (4 ft. 0 in.)	1229 mm (48 in.) (4 ft. 0 in.)	1229 mm (48 in.) (4 ft. 0 in.)	—	—	1258 mm (49.5 in.) (4 ft. 1.5 in.)
SAE Capacity	3.9 m ³ (5.2 cu. yd.)	4.3 m ³ (5.6 cu. yd.)	4.5 m ³ (5.9 cu. yd.)	—	—	4.1 m ³ (5.4 cu. yd.)
Weight	1251 kg (2,758 lb.)	1330 kg (2,932 lb.)	1397 kg (3,080 lb.)	—	—	1561 kg (3,441 lb.)
C-Frame Assembly Weight (without blade)	1647 kg (3,631 lb.)	1647 kg (3,631 lb.)	1647 kg (3,631 lb.)	—	—	2101 kg (4,622 lb.)
J Blade Angle	23.8 deg.	23.8 deg.	23.8 deg.	—	—	—
K Overall Width with Blade Angled	3391 mm (134 in.) (11 ft. 2 in.)	3658 mm (144 in.) (12 ft. 0 in.)	3901 mm (154 in.) (12 ft. 10 in.)	—	—	—
L Blade Tilt (uses tilt jack)	508 mm (20 in.)	533 mm (21 in.)	572 mm (23 in.)	—	—	—
M Cut Reach	158 mm (6.2 in.)	145 mm (5.7 in.)	109 mm (4.3 in.)	—	—	—
N Width Over Track	2693 mm (106 in.) (8 ft. 10 in.)	2997 mm (118 in.) (9 ft. 10 in.)	3302 mm (130 in.) (10 ft. 10 in.)	—	—	—
O Cast Reach	284 mm (11.2 in.)	272 mm (10.7 in.)	234 mm (9.2 in.)	—	—	—

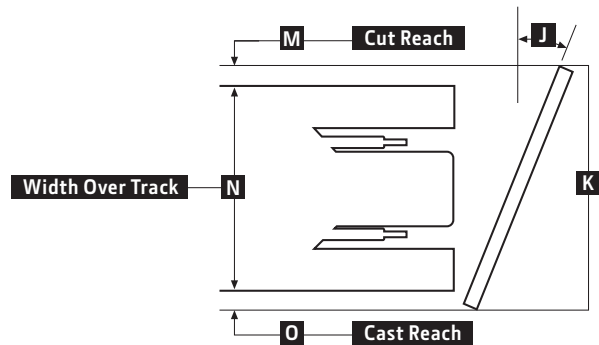
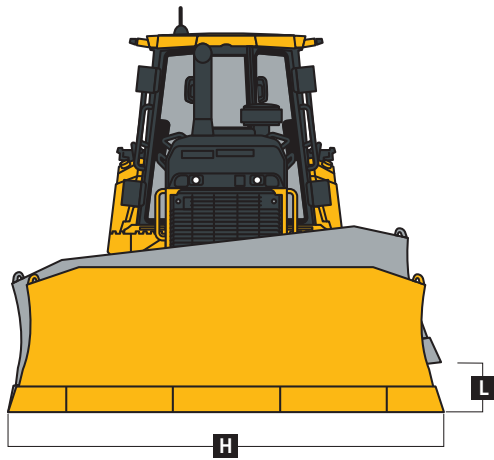

Rear Ripper

850K XLT / 850K WLT / 850K LGP / 850K / 850K WT

Multi-shank (3) parallelogram ripper with hydraulic pitch adjustment and ESCO® ripper tips

Weight	2032 kg (4,480 lb.)
P Maximum Penetration	724 mm (28.5 in.)
Q Maximum Clearance Under Tip	610 mm (24 in.)
R Overall Length, Lowered Position	1626 mm (5 ft. 4 in.)
R^l Overall Length, Raised Position	1525 mm (5 ft. 0 in.)
S Overall Beam Width	2400 mm (7 ft. 10 in.)
T Slope Angle (full raise)	24 deg.
U Ripping Width	2146 mm (7 ft. 1 in.)
V Distance Between Shanks	1041 mm (3 ft. 5 in.)

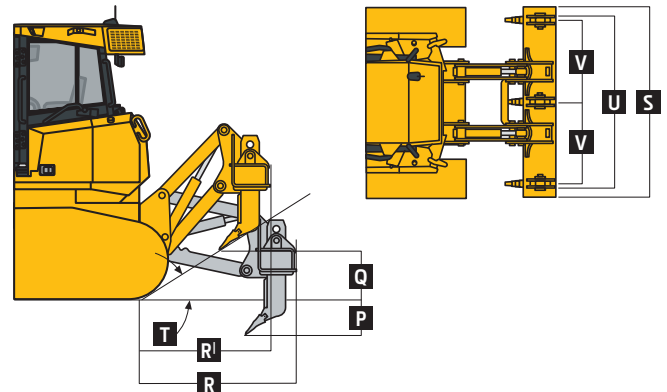

Additional equipment

Key: ● Standard ▲ Optional or special

See your John Deere dealer for further information.

750K	850K	Engine
●	●	Meets EPA Final Tier 4/EU Stage IV emissions
●	●	John Deere PowerTech™ PVS 6.8L engine
	●	John Deere PowerTech™ PSS 6.8L engine
●	●	Wet-sleeve cylinder liners
●	●	Eco mode
●	●	Exhaust stack, black
▲	▲	Exhaust stack, chrome
●	●	Electronic control with automatic engine protection
●	●	Turbocharged and air-to-air aftercooled
●	●	Dual-element dry canister with external rotary ejector precleaner
●	●	Programmable auto engine shutdown
●	●	Automatic turbo cool-down timer
●	●	Fuel filters with automatic electronic priming
▲	▲	Severe-duty fuel filter
▲	▲	Engine block heater
▲	▲	Engine coolant heater, fuel fired
▲	▲	100-amp alternator (canopy)
▲	▲	130-amp alternator (cab)
Cooling		
●	●	Tilt-out cooling fan, hydraulically driven, variable-speed suction type
●	●	Engine cooling rated -37 deg. C (-34 deg. F)
●	●	Automatic, programmable reversing fan
●	●	Engine radiator, 10 fins per in.
●	●	Hydrostatic (HST) cooler, 10 fins per in.
●	●	Hydraulic cooler, 10 fins per in.
●	●	Enclosed safety fan guard (conforms to SAE J1308 and ISO 3457)
●	●	Cooling package isolated from engine compartment
●	●	Heavy-duty, trash-resistant radiator and high-ambient cooling package
Powertrain		
●	●	Dual-path HST transmission
●	●	Selectable reverse-speed ratios
●	●	Operator-selectable decelerator function (hydrostats and engine or hydrostats only)
●	●	Single-lever steering with counterrotate function
●	●	Full power turns with infinitely variable track speed
●	●	HST (dynamic) service brakes
●	●	Wet, multi-disc parking brake
●	●	Remote diagnostic test ports
●	●	Automatic cold-weather transmission warm-up system
●	●	Automatic transmission derating for exceeded system temperatures
●	●	Sealed dedicated transmission reservoir and filtration system separate from hydraulic system

750K	850K	Hydraulic System
●	●	Load-sense electrohydraulic (EH) system with variable-displacement piston pump
●	●	2-function hydraulics
▲	▲	3-function hydraulics
▲	▲	3-function hydraulics with rear plumbing
▲	▲	4-function hydraulics with rear plumbing
▲	▲	Grade-control-ready EH hydraulics
●	●	Hydrau™ All-Season Hydraulic Oil, -25 deg. C to 50 deg. C (-13 deg. F to 122 deg. F)
▲	▲	Hydrau™ XR Hydraulic Oil, -40 deg. C to 40 deg. C (-40 deg. F to 104 deg. F)
▲	▲	Power pitch for outside dozer
●	●	Hydraulic pump, standard
▲	▲	Hydraulic pump, high flow
▲	▲	Hydraulic pump for direct-drive winch
●	●	Sealed dedicated hydraulic reservoir and filtration system separate from transmission system
Undercarriage		
●	●	Full-length, smooth-surface track frame covers
●	●	Guides, front and rear, with wear strips
●	●	Segmented sprockets
●	●	Double-flange rollers
●	●	Oscillating undercarriage
●	●	Heavy-duty sealed and lubricated undercarriage
▲	▲	Extended life undercarriage SC-2™ bushings
▲	▲	Full-length rock guards
	▲	Recessed sprockets
Operator's Station		
▲	▲	Canopy cab
▲	▲	Enclosed cab with air/heat
●	●	Retractable seat belt, 76 mm (3 in.) (conforms to SAE J386)
▲	▲	Air-suspension vinyl seat (canopy)
▲	▲	Air-suspension cloth seat (enclosed cab)
▲	▲	Air-suspension heated deluxe seat (enclosed cab)
●	●	AM/FM radio
▲	▲	XM Satellite Radio™
▲	▲	HVAC-powered precleaner
●	●	Tilting cab
●	●	Multifunction, multi-language LCD monitor
▲	▲	178-mm (7 in.) color, multi-language Primary Display Unit (PDU) (with EH hydraulics only)
●	●	Backup alarm
●	●	12-volt accessory plug (1)
▲	▲	12-volt accessory plug (2)
●	●	Keyless start
▲	▲	Rear attachments mirror
●	●	Convex interior rearview mirror
●	●	Lockable, dash-mounted storage compartment
●	●	Cup holders (2)
Overall Vehicle		
●	●	Tilt operator station service access
●	●	Environmental drain package
▲	▲	Fluid-sample valves

750K	850K	Overall Vehicle (continued)			
●	●	JDLink™ Ultimate wireless machine communication system (available in specific countries; see your local dealer for details)			
▲	▲	Quick service ports (HST, hydraulic, and engine oil, and coolant)			
▲	▲	Fast-fuel system			
●	●	Lights, grille mounted (2), rear mounted (2)			
▲	▲	Additional lights (2)			
●	●	Engine-compartment light			
▲	▲	Beacon light			
▲	▲	Topcon grade-control system			
▲	▲	Topcon-ready interface package			
▲	▲	Trimble-ready interface package			
▲	▲	Leica-ready interface package			
▲	▲	Forestry protection package			
●	●	Master electrical disconnect switch			
750K	850K	Attachments			
	▲	Landfill package			
▲	▲	Pitch jack			
▲	▲	Rollover Protective Structure (ROPS) heater			
▲	▲	Cab mounts and isolators for forestry package			
▲	▲	Large debris prescreen			
▲	▲	Full-length rock guards			
▲	▲	Recessed sprockets			
▲	▲	Final-drive trash guards (trash applications)			
▲	▲	Rear ripper/scarifier			
▲	▲	Rear counterweight (1 or 2)			
▲	▲	Heavy-duty grille			
▲	▲	Retrieval hitch with 1 or 2 counterweights			
▲	▲	Extended rigid drawbar			
▲	▲	Extended rigid drawbar with 2 counterweights			
▲	▲	Rear storage compartment			
▲	▲	Corrosion prevention			
STD	XLT	LGP	750K Shoes		
●	●	▲	560-mm (22 in.) moderate service		
▲	▲	▲	560-mm (22 in.) extreme service		
▲	▲	▲	610-mm (24 in.) moderate service		
▲	▲	▲	610-mm (24 in.) extreme service		
		▲	710-mm (28 in.) moderate service		
		●	865-mm (34 in.) moderate service with clipped corners		
STD	WT	XLT	WLT	LGP	850K Shoes
▲	▲	▲	▲	▲	560-mm (22 in.) extreme service
●	▲	●	▲	▲	610-mm (24 in.) moderate service
▲	▲	▲	▲	▲	610-mm (24 in.) extreme service
	●	●	▲	▲	760-mm (30 in.) moderate service with clipped corners
	▲		▲	▲	760-mm (30 in.) extreme service with clipped corners
				●	910-mm (36 in.) moderate service with clipped corners
				▲	910-mm (36 in.) extreme service with clipped corners

Net engine power is with standard equipment including air cleaner, exhaust system, alternator, and cooling fan at test conditions specified per ISO9249. No derating is required up to 3050-m (10,000 ft.) altitude. Also available: winches, fair-leads, log arches, skidding grapples, trash packages, landfill protection packages, cable plows, side booms, field-installed cab for canopy, canopy heater, and fire-suppression systems. Specifications and design subject to change without notice. Wherever applicable, specifications are in accordance with SAE standards. Except where otherwise noted, these specifications are based on units with ROPS, full fuel tanks, and 79-kg (175 lb.) operators; 750K XLT unit with rigid drawbar, 560-mm (22 in.) track shoes, and PAT blade; 750K LGP unit with rigid drawbar, 865-mm (34 in.) track shoes, and PAT blade; 750K unit with rigid drawbar, 560-mm (22 in.) track shoes, and OSD blade; 850K WT unit with 760-mm (30 in.) track shoes and OSD blade; 850K XLT unit with 610-mm (24 in.) track shoes and PAT blade; 850K WLT unit with 760-mm (30 in.) track shoes and PAT blade; 850K LGP unit with 910-mm (36 in.) track shoes and OSD or PAT blade; and 850K unit with 610-mm (24 in.) track shoes and OSD blade. Operator station ROPS and FOPS certified.

